

18ft PRO II WB ENCLOSED TRAILER

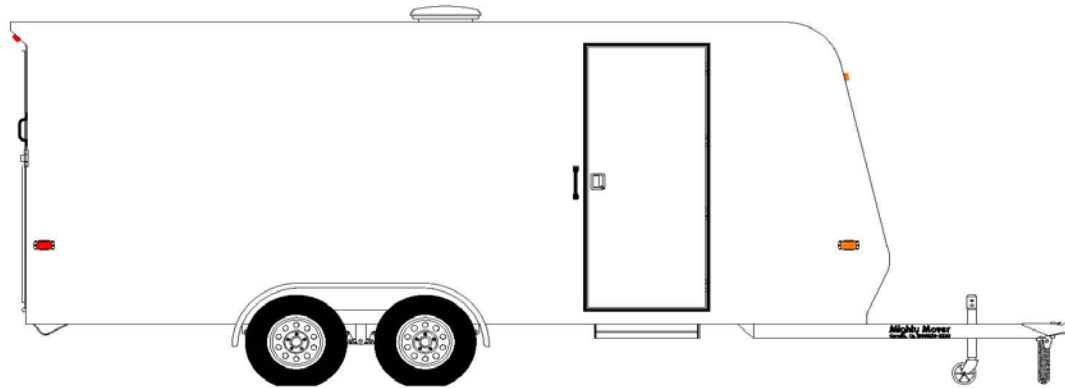

BODY LENGTH	18ft 0in	G.V.W.R. (lbs)	7,000lbs	INTERIOR LENGTH	17ft 9in
BODY WIDTH	8ft 6in	G.A.W.R. (lbs)	7,000lbs	INTERIOR HEIGHT	6ft 6in
OVERALL LENGTH	23ft 0in	CURB WEIGHT (lbs)	2,950lbs	INTERIOR WIDTH	8ft 3in between side walls
OVERALL WIDTH	8ft 6in	PAYLOAD (lbs)	4,050lbs	INTERIOR WIDTH	8ft 1in between bumper rails
OVERALL HEIGHT	8ft 11in	HITCH WEIGHT	10 - 15%	INTERIOR WIDTH	7ft 1in between wheel wells
DECK HEIGHT	22in	CUBIC CAPACITY	950cu ft	REAR DOOR HEIGHT	6ft 1in
BALL HEIGHT	17in	HITCH	2-5/16in ball coupler	REAR DOOR WIDTH	8ft 2in

Options

Floor Plan

Curb Side View

Street Side View

End View

- 7,000lb G.V.W. Rating
- 53in Long Tongue - Front Crossmember to the Center of the Ball
- Heavy Duty 2-5/16in Ball Coupler
- Heavy Duty Dual Safety Chains with Hooks (DOT standard)
- Fully Compliant D.O.T. Regulation Light Package
- Lighting Complies with all Applicable Requirements Prescribed by FMVSS/CMVSS 108
- 7-way Flat Pin Trailer Electrical Connector (tow package standard)
- Heavy Duty 1500lb Capacity Swivel Landing Jack with Caster
- White Modular Style 15"x 6" Wheels with 5 on 4-1/2" Bolt Circle
- ST205/75D-15" Load Range "C" Tires
- Tandem 3,500lb Straight Axles with Leaf Spring Suspension
- 10"x 2-1/4" Electric Brakes on Both Axles
- Emergency Break-Away System
- Bolted on, Painted Steel Rounded Fenders
- White .040 Pre-Finished Exterior Smooth Aluminum Skin, Bonded - No Fasteners
- White 3 mil Vinyl Coated Walls and Ceiling
- 30"x 72" RV Style Side Entry Door with Flush Latch
- Slide-Out Side Door Convenience Step
- Bright Aluminum Diamond Plate or Stainless Steel Front Rock Guard
- White Smooth Full Width Spring Assisted Rear Ramp Door
- Aluminum Diamond Plate Ramp Door Edge Protector
- All Steel Welded 4" Box Tube Mainframe
- 1-1/2"x 1" Rectangular Tubing Wall Uprights on 24" Centers
- 1-1/2"x 1" Rectangular Tubing Roof Bows on 24" Centers
- 3/4" Tongue & Groove Plywood Floor with Marine Varnish
- 1" Sq. Tubing Tie Bar Both Sides with 3/8" Welded Tie Down Loops
- One (1) 12 Volt Interior Dome Lights with Wall Switch
- One (1) Manual Crank-up Roof Vents
- Spare Tire Mount (Spare Tire and Wheel Optional)

18ft Pro II Enclosed Trailer

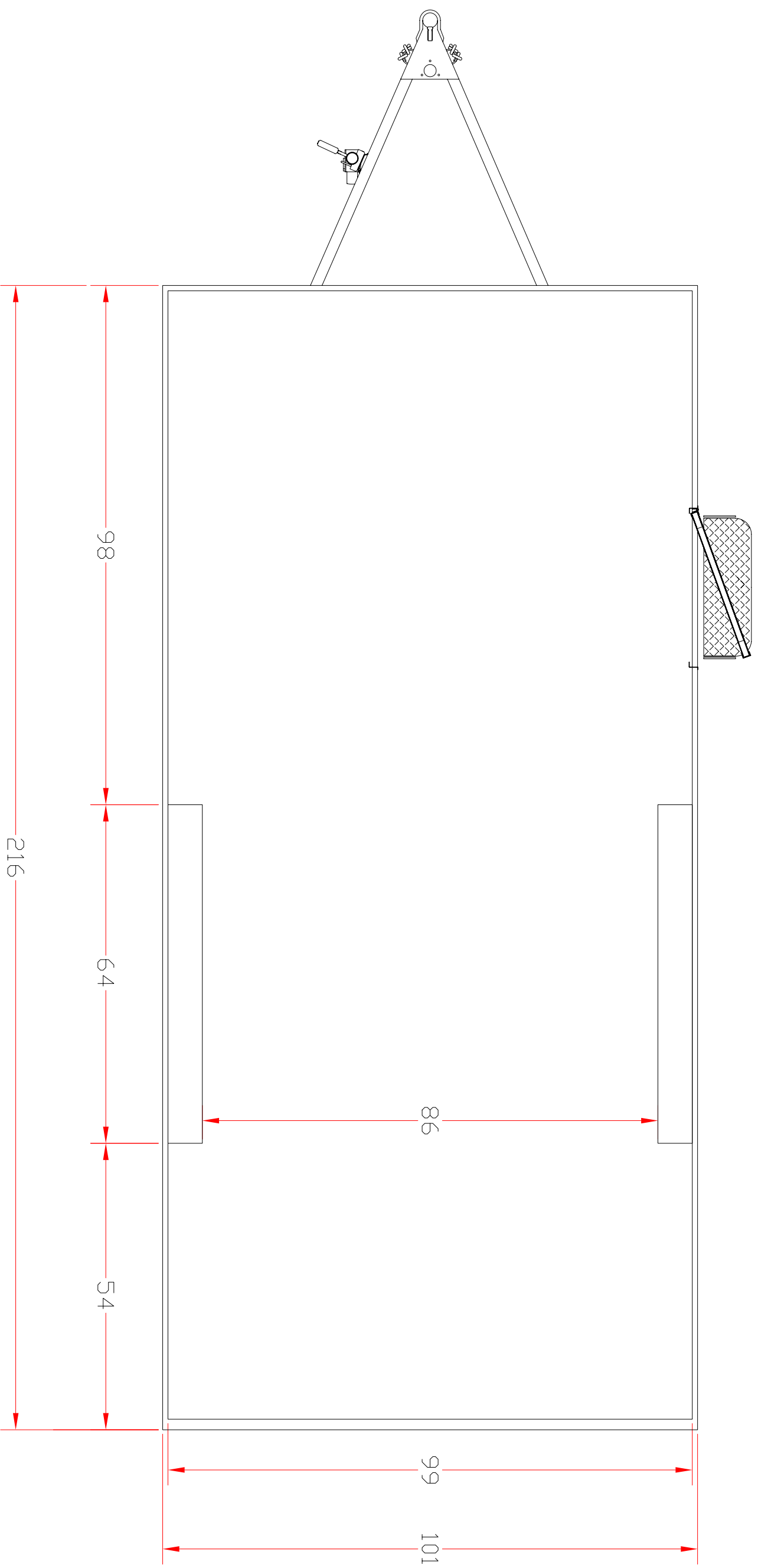

18ft Pro II Enclosed Trailer

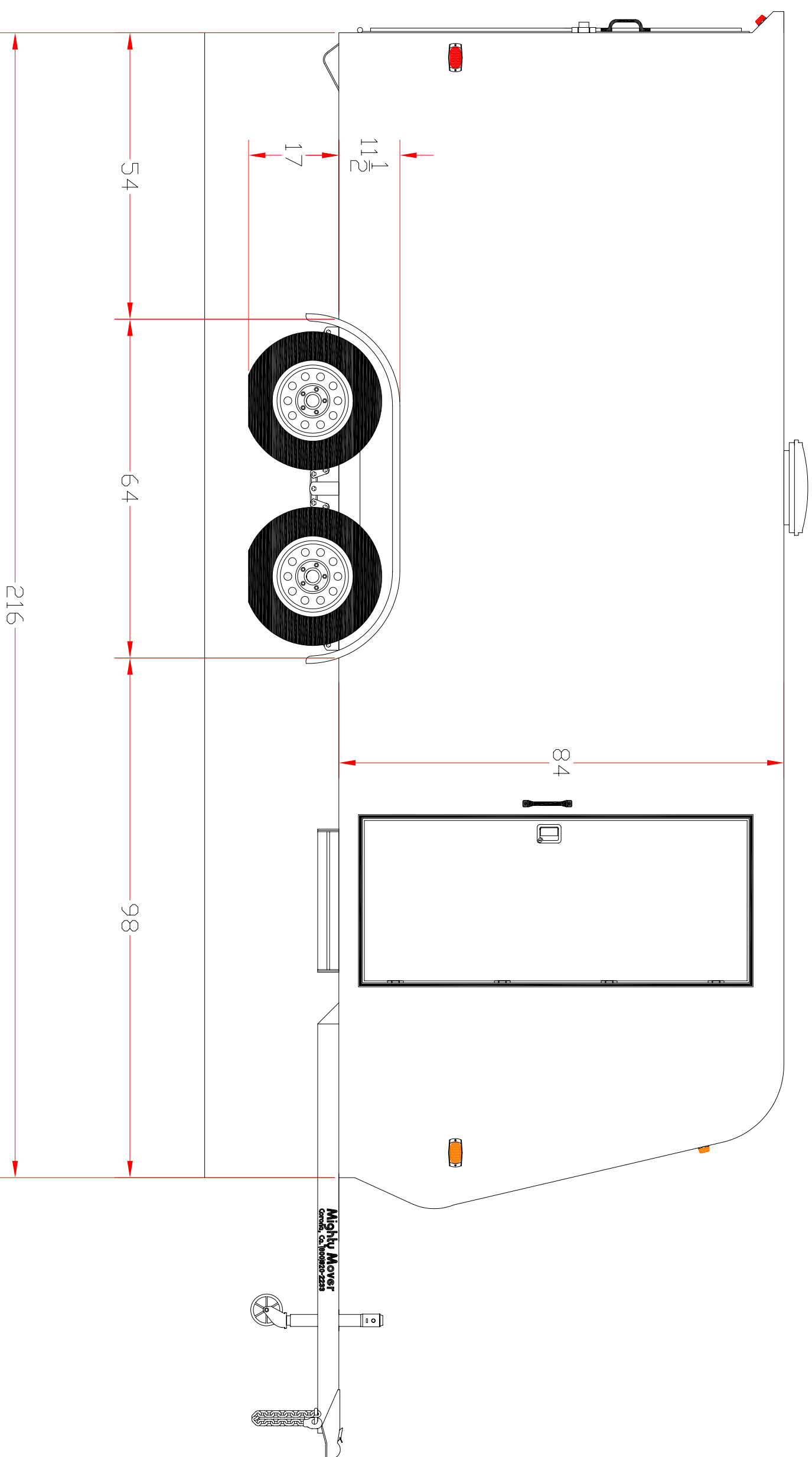

18ft Pro II Enclosed Trailer

